

Kingspan Insulation Ltd

Pembridge
Leominster
Herefordshire HR6 9LA

Tel: 01544 387382 Fax: 01544 387482

e-mail: technical@kingspantek.co.uk

website: www.kingspantek.co.uk



Agrément Certificate

02/S029

Product Sheet 1

KINGSPAN STRUCTURAL INSULATED PANEL (SIP) SYSTEMS

KINGSPAN TEK BUILDING SYSTEM

This Agrément Certificate Product Sheet⁽¹⁾ relates to the Kingspan TEK Building System, loadbearing wall and roof panels comprising structural insulated panels (SIPs) manufactured from OSB/3 and rigid urethane insulation. The system is for use above the damp-proof course in domestic applications up to and including four storeys high (subject to national height restrictions) as the load-bearing inner leaf of an external cavity wall, or as part of separating walls, internal loadbearing walls or flat and pitched roofs.

(1) Hereinafter referred to as 'Certificate'.

CERTIFICATION INCLUDES:

- factors relating to compliance with Building Regulations where applicable
- factors relating to additional non-regulatory information where applicable
- independently verified technical specification
- assessment criteria and technical investigations
- design considerations
- installation guidance
- regular surveillance of production
- formal three-yearly review.

KEY FACTORS ASSESSED

Strength and stability — the panels have adequate strength and stiffness to resist the loads associated with installation and in-service loading (see section 6).

Thermal performance — the system contributes to the overall performance of the wall and roof construction (see section 7).

Condensation — walls and roofs can adequately limit the risk of surface and interstitial condensation (see section 8).

Behaviour in relation to fire — the Certificate holder has not declared a reaction to fire classification for the complete system in accordance with BS EN 13501-1 : 2018. Constructions including the system can achieve resistance to fire classifications of REI30 and REI60 to BS EN 13501-2 : 2016 (see section 9).

Resistance to airborne sound — separating walls used in conjunction with suitable linings and flanking elements can provide sufficient resistance to airborne sound (see section 12).

Durability — provided the installation remains weathertight, the SIPs will have a 60-year minimum service life provided they are protected from damage by the external and internal finishes (see section 15).



The BBA has awarded this Certificate to the company named above for the system described herein. This system has been assessed by the BBA as being fit for its intended use provided it is installed, used and maintained as set out in this Certificate.

On behalf of the British Board of Agrément

Date of Seventh issue: 27 September 2021

Originally certificated on 17 December 2002

Hardy Giesler
Chief Executive Officer

The BBA is a UKAS accredited certification body – Number 113.

*The schedule of the current scope of accreditation for product certification is available in pdf format via the UKAS link on the BBA website at www.bbacerts.co.uk
Readers MUST check the validity and latest issue number of this Agrément Certificate by either referring to the BBA website or contacting the BBA directly.*

Any photographs are for illustrative purposes only, do not constitute advice and should not be relied upon.

British Board of Agrément

Bucknalls Lane
Watford
Herts WD25 9BA

tel: 01923 665300
clientservices@bbacerts.co.uk
www.bbacerts.co.uk

©2021

Regulations

In the opinion of the BBA, the Kingspan TEK Building System, if installed, used and maintained in accordance with this Certificate, can satisfy or contribute to satisfying the relevant requirements of the following Building Regulations (the presence of a UK map indicates that the subject is related to the Building Regulations in the region or regions of the UK depicted):



The Building Regulations 2010 (England and Wales) (as amended)

Requirement: A1 Comment:	Loading Walls and roofs constructed from the panels will have sufficient strength and stiffness when designed and constructed in accordance with sections 6.1, 6.2, 6.4 and 6.5 of this Certificate.
Requirement: A3 Comment:	Disproportionate collapse Wall panels can contribute to a construction satisfying this Requirement. See section 6.8 of this Certificate.
Requirement: B3(1)(2)(3)(a) Comment:	Internal fire spread (structure) The wall panels can contribute to satisfying this Requirement. See section 9.5 of this Certificate.
Requirement: B3(4) Comment:	Internal fire spread (structure) The panels are restricted by this Requirement. See sections 9.1 and 9.2 of this Certificate.
Requirement: B4(1) Comment:	External fire spread The panels are restricted by this Requirement. See sections 9.1 and 9.3 of this Certificate.
Requirement: C2(c) Comment:	Resistance to moisture Wall and roof panels can adequately limit the risk of surface condensation and contribute to minimising the risk of interstitial condensation. See sections 8.1 to 8.3 of this Certificate.
Requirement: E1 Comment:	Protection against sound from other parts of the building and adjoining buildings When installed with suitable linings and flanking elements, separating walls incorporating the panels can satisfy this Requirement. See section 12 of this Certificate.
Requirement: E2(a) Comment:	Protection against sound within a dwelling-house etc A single-leaf, non-loadbearing partition incorporating the panel, with suitable plasterboard linings, can satisfy this Requirement. See section 12 of this Certificate.
Requirement: L1(a)(i) Comment:	Conservation of fuel and power The panels can contribute to satisfying this Requirement, although compensating measures may be required in Wales. See sections 7 and 10.1 of this Certificate.
Regulation: 7(1) Comment:	Materials and workmanship The panels are acceptable. See section 15.1 and the <i>Installation</i> part of this Certificate.
Regulation: 7(2) Comment:	Materials and workmanship The wall panels are restricted by this Regulation. See sections 9.1 and 9.3 of this Certificate.

Regulation:	26	CO₂ emission rates for new buildings
Regulation:	26A	Fabric energy efficiency rates for new dwellings (applicable to England only)
Regulation:	26A	Primary energy consumption rates for new buildings (applicable to Wales only)
Regulation:	26B	Fabric performance values for new dwellings (applicable to Wales only)
Comment:		The panels can contribute to satisfying these Regulations, although compensating fabric and or services measures may be required. See sections 7 and 10.1 of this Certificate.



The Building (Scotland) Regulations 2004 (as amended)

Regulation:	8(1)	Durability, workmanship and fitness of materials
Comment:		The panels can contribute to a construction satisfying this Standard. See sections 14 and 15.1 and the <i>Installation</i> part of this Certificate.
Regulation:	9	Building standards applicable to construction
Standard:	1.1(a)	Structure
Comment:		Walls and roofs incorporating the panels will have sufficient strength and stiffness when designed and constructed in accordance with sections 6.1, 6.2, 6.4 and 6.5 of this Certificate, with reference to clauses 1.1.1 ⁽¹⁾ and (when suitably reinforced) 1.1.2 ⁽¹⁾ of this Standard.
Standard:	1.2	Disproportionate collapse
Comment:		Wall panels can contribute to a construction satisfying the requirements of this Standard, with reference to clause 1.2.1 ⁽¹⁾ . See section 6.8 of this Certificate.
Standard:	2.2	Separation
Comment:		Walls incorporating the product can contribute to satisfying this Standard, with reference to clauses 2.2.1 ⁽¹⁾ , 2.2.2 ⁽¹⁾ , 2.2.4 ⁽¹⁾ , 2.2.5 ⁽¹⁾ and 2.2.6 ⁽¹⁾ . See sections 9.1, 9.5 and 9.8 of this Certificate.
Standard:	2.3	Structural protection
Comment:		Walls incorporating the product can contribute to satisfying this Standard, with reference to clauses 2.3.1 ⁽¹⁾ , 2.3.2 ⁽¹⁾ , 2.3.3 ⁽¹⁾ and 2.3.5 ⁽¹⁾ . See sections 9.1, 9.5 and 9.8 of this Certificate.
Standard:	2.4	Cavities
Comment:		Walls incorporating the product are restricted by this Standard, with reference to clause 2.4.2 ⁽¹⁾ . See sections 9.1 and 9.2 of this Certificate.
Standard:	2.6	Spread to neighbouring buildings
Comment:		Walls incorporating the product can contribute to satisfying this Standard, with reference to clauses 2.6.1 ⁽¹⁾ and 2.6.6 ⁽¹⁾ and are restricted in some cases with reference to clauses 2.6.4 ⁽¹⁾ and 2.6.5 ⁽¹⁾ . See sections 9.1 and 9.4 of this Certificate.
Standard:	2.7	External wall cladding
Comment:		The panels use as infill panels is restricted by this Standard in some cases, with reference to clause 2.7.1 ⁽¹⁾ . See sections 9.1 and 9.4 of this Certificate.
Standard:	3.15	Condensation
Comment:		The panels can adequately limit the risk of surface and interstitial condensation, with reference to clauses 3.15.1 ⁽¹⁾ to 3.15.4 ⁽¹⁾ of this Standard. See sections 8.1 to 8.3 of this Certificate.
Standard:	5.1	Noise separation
Comment:		Separating walls with suitable linings and flanking elements can satisfy this Standard, with reference to clauses 5.1.1 ⁽¹⁾ , 5.1.2 ⁽¹⁾ and 5.1.4 ⁽¹⁾ . See section 12 of this Certificate.

Standard: Comment:	5.2	Noise reduction between rooms Internal walls with suitable linings can satisfy this Standard, with reference to clauses 5.2.1 ⁽¹⁾ and 5.2.2 ⁽¹⁾ . See section 12 of this Certificate.
Standard: Comment:	6.1(b)	Carbon dioxide emissions The panels can contribute to satisfying this Standard, with reference to clauses 6.1.2 ⁽¹⁾ and 6.1.6 ⁽¹⁾ . Compensating fabric and/or services measures may be required. See sections 7 and 10.1 of this Certificate.
Standard: Comment:	6.2	Building insulation envelope The panels can contribute to satisfying this Standard, with reference to clauses 6.2.1 ⁽¹⁾ , 6.2.3 ⁽¹⁾ and 6.2.4 ⁽¹⁾ , although compensating fabric measures may be required. See sections 7 and 10.1 of this Certificate.
Standard: Comment:	7.1(a)(b)	Statement of sustainability The system can contribute to satisfying the relevant requirements of Regulation 9, Standards 1 to 6, and therefore will contribute to a construction meeting a bronze level of sustainability as defined in this Standard. See section 7 of this Certificate.
Regulation: Comment:	12	Building standards applicable to conversions All comments given for the system under Regulation 9, Standards 1 to 6, also apply to this Regulation, with reference to clause 0.12.1 ⁽¹⁾ and Schedule 6 ⁽¹⁾ .

(1) Technical Handbook (Domestic).



The Building Regulations (Northern Ireland) 2012 (as amended)

Regulation: Comment:	23(a)(i) (iii)(b)(i)	Fitness of materials and workmanship The system is acceptable. See section 15.1 and the <i>Installation</i> part of this Certificate.
Regulation: Comment:	29	Condensation The panels can contribute to minimising the risk of interstitial condensation. See sections 8.2 and 8.3 of this Certificate.
Regulation: Comment:	30	Stability Walls and roofs constructed from the panels will have sufficient strength and stiffness to satisfy this Regulation, when designed and constructed in accordance with sections 6.1, 6.2, 6.4 and 6.5 of this Certificate.
Regulation: Comment:	31	Disproportionate collapse Wall panels can contribute to a construction satisfying this Regulation. See section 6.8 of this Certificate.
Regulation: Comment:	35(1)(2)(3)	Internal fire spread – Structure The wall panels can contribute to satisfying this Regulation. See section 9.5 of this Certificate.
Regulation: Comment:	35(4)	Internal fire spread – Structure The panels are restricted by this Requirement. See sections 9.1 and 9.2 of this Certificate.
Regulation: Comment:	36(a)	External fire spread The panels are restricted by this Regulation. See sections 9.1 and 9.3 of this Certificate.
Regulation: Comment:	39(a)(i)	Conservation measures The panels can contribute to satisfying this Regulation. See sections 7 and 10.1 of this Certificate.

Regulation:	40(2)	Target carbon dioxide emission rate
Comment:		The panels can contribute to satisfying this Regulation. See sections 7 and 10.1 of this Certificate.
Regulation:	49	Protection against sound from other parts of the building and from adjoining buildings
Comment:		When installed with suitable flanking elements, separating walls incorporating the panels can satisfy this Regulation. See section 12 of this Certificate.
Regulation:	50(a)	Protection against sound within a dwelling or room for residential purposes
Comment:		A single-leaf, non-loadbearing partition incorporating the panel, with suitable plasterboard linings, can satisfy this Regulation. See section 12 of this Certificate.

Construction (Design and Management) Regulations 2015 Construction (Design and Management) Regulations (Northern Ireland) 2016

Information in this Certificate may assist the client, designer (including Principal Designer) and contractor (including Principal Contractor) to address their obligations under these Regulations.

See section: 3 *Delivery and site handling* (3.1) of this Certificate.

Additional Information

NHBC Standards 2021

In the opinion of the BBA, Kingspan TEK Building System, if installed, used and maintained in accordance with this Certificate, can contribute to satisfying the relevant requirements in relation to *NHBC Standards*, Part 6 *Superstructure (excluding roofs)*, Chapter 6.2 *External timber framed walls*, and Part 7 *Roofs*, Chapters 7.1 *Flat Roofs, Terraces and Balconies* and 7.2 *Pitched roofs*.

Technical Specification

1 Description

1.1 Each panel of the Kingspan TEK Building System is nominally 142 ('Tek 142') or 172 mm ('Tek 172') thick overall, with two outer skins of 15 mm thick OSB/3 (oriented strand board type 3), separated by a core of 112 or 142 mm thick zero-rated ozone-depleting potential (ODP) rigid urethane insulation (PUR). The panel mass is approximately 25 kg·m⁻² for each panel thickness (142 and 172 mm).

1.2 The panels are available in 200 to 1220 mm widths and up to 7500 mm lengths, in the appropriate shapes and sizes for each project, together with any expanding urethane sealant, fixings and jointing pieces that may be required.

1.3 For each project, an inventory of components is manufactured from working drawings generated by the Certificate holder (or one of their appointed agents) in accordance with the client's approved design.

1.4 In addition to the panels, a number of other components are required to facilitate the assembly of the system:

For the 142 mm thick panels:

- edge timbers — minimum 50 by 110 mm grade C16 or equivalent, tolerance class T2 to BS EN 336 : 2013
- structural timber posts — minimum 100 by 110 mm grade C24 or equivalent, tolerance class T2 to BS EN 336 : 2013
- insulated splines — 100 mm (w) by 110 mm (d), comprising two OSB/3, 15 by 100 mm skins and rigid urethane insulation core (see Figure 2).

For the 172 mm thick panels:

- edge timbers — minimum 38 by 140 mm grade C16 or equivalent, tolerance class T2 to BS EN 336 : 2013
- structural timber posts — minimum 80 by 140 mm grade C24 or equivalent, tolerance class T2 to BS EN 336 : 2013
- insulated splines — 80 mm (w) by 140 mm (d), comprising two OSB/3, 15 by 80 mm skins and rigid urethane insulation core (see Figure 2).

1.5 Ancillary items to be used with the system but outside the scope of the Certificate are:

- other structural components such as engineered timber TJI joists, beams, structural steel — detailed and specified as necessary
- damp-proof course (dpc) — installed in accordance with BS EN 1996-2 : 2006, PD 6697 : 2019, BS 8000-3 : 2001 and BS 8215 : 1991, with a minimum 1.2 mm thickness and 1.5 kg·m⁻² weight
- levelling shims — high-density, polyethylene (>99% of density >962 kg·m⁻³, available in 2 to 6 mm thicknesses
- sole plate grout — proprietary, injectable mortar grouting, to exceed the properties of a Class 1 mortar as defined in BS EN 1996-2 : 2006 and PD 6697 : 2019
- silicone — one-part transparent silicone of density >1020 kg·m⁻³, permissible deformation >25%, UV — used as fungal-resistant and water-repellent coating — see *Installation* part for silicone application
- tape — used for joints 150 mm x 48 mm in accordance with BS EN 13963 : 2014
- Gyproc acoustic sealant caulk or similar — an acrylic sealant and adhesive used for sealing air gaps and joints to maintain acoustic performance in separating walls to BS EN 15651-1 : 2017 — see Figure 6
- expanding urethane — gun-grade polyurethane-based expanding one-part foam
- FastenMaster Headlok screws or equivalent — epoxy-coated carbon steel screws, 4.8 mm diameter by 73 to 254 mm long
- machine nails — galvanized/sherardized ringshank machine nails (in coils or strips) in accordance with BS EN 1995-1-1 : 2004, sizes 2.8 by 63 mm and 3.1 by 90 mm
- standard nails — as per BS EN 1995-1-1 : 2004
- joist hangers — as specified for the project. All fixings to be in accordance with the manufacturer's instructions
- dry lining battens — minimum 50 mm wide by 10 mm deep softwood battens, or vertical metal rails
- floor decking — 22 mm TG4 OSB/3 or 22 mm P5 TG4 particle board (protected) — size of boards to suit joist centres
- sole plates — treated C24 to BS EN 338 : 2016, 140 by 38 mm (minimum, nominal UK size 145 by 47 mm) for 142 mm thick panels and 172 by 40 mm (minimum) for 172 mm thick panels
- wall ties — Simpson Strong-Tie SWT-50 TEK wall-tie kits to BS EN 845-1 : 2013, using flange-head 4 by 30 mm stainless steel screws
- counter battens — treated softwood counter battens, minimum 50 mm wide by 25 mm deep
- tiling/slate battens — sizing as per BS 5534 : 2014
- vapour permeable underlay/membrane for roofing and walls — Kingspan Roof Tile Underlays (BBA Certificate 11/4870)

2 Manufacture

2.1 Kingspan TEK SIPs consist of a high-performance fibre-free rigid PUR core autohesively bonded to 2 x 15 mm grade 3 OSB during manufacture. The panels are cured and then cut to the desired length by a computer-controlled machine cutter, to agreed specifications or in accordance with British Standards and this Certificate. Each panel is marked with the production date and time, panel dimensions and process order number, along with the BBA logo and Certificate number. Quality checks are made during the manufacturing process and on the finished components. They are delivered on site as a complete panel.

2.2 As part of the assessment and ongoing surveillance of product quality, the BBA has:

- agreed with the manufacturer the quality control procedures and product testing to be undertaken
- assessed and agreed the quality control operated over batches of incoming materials
- monitored the production process and verified that it is in accordance with the documented process
- evaluated the process for management of nonconformities
- checked that equipment has been properly tested and calibrated
- undertaken to carry out the above measures on a regular basis through a surveillance process, to verify that the specifications and quality control being operated by the manufacturer are being maintained.

2.3 The management system of Kingspan Insulation Limited has been assessed and registered as meeting the requirements of BS EN ISO 9001 : 2015 by the Loss Prevention Certification Board (LPCB) (Certificate 388-3QMS-05).

3 Delivery and site handling

3.1 The panels are delivered in shrink-wrap, with edge protectors and banded packaging used for initial transit and temporary protection. They should be stored flat, no more than 16 panels high, over suitable stillage to a slight fall to allow rain run-off. Bearers should be at 600 mm (maximum) centres (end bearers no more than 150 mm from the edge of the panel) and aligned vertically between individual packs in accordance with the Certificate holder's guidelines.

3.2 The panels and all components should be stored inside, or in dry, sheltered conditions, at least 150 mm off the ground, and covered with opaque polythene sheeting or tarpaulin until the panels and components are to be used.

3.3 The panels can withstand the normal loads associated with site handling and installation. Damaged panels should not be used.

Assessment and Technical Investigations

The following is a summary of the assessment and technical investigations carried out on the Kingspan TEK Building System.

Design Considerations

4 Use

4.1 The Kingspan TEK Building System panels are suitable for use as loadbearing partitions, separating walls, the inner leaf of external cavity walls, and pitched and flat (with a minimum of 1.15° design slope) roofs in dwellings up to and including four storeys high including a room in the roof (except where national height restrictions apply), subject to the provision of solid timber spline studs at ground level (see Figures 1 and 2 and Table 1). The panels may also be used as infill panels in multi-storey framed buildings subject to design constraints on height and the method of fixing to the structural frame. All fixings must be designed to allow movement within the structural frame due to expansion/contraction or differential movement. However, the panels are not suitable to be used for structural flooring construction.

4.2 All structural calculations must be undertaken by a Chartered Structural Engineer, who must contact the Certificate holder for application guidance for the system. All production drawings should be carried out by the Certificate holder, or one of their approved designers in accordance with the standard details and design manuals for the system (the latest version of which can be requested from the Certificate holder).

4.3 Any cutting or forming of openings within wall or roof panels must be considered carefully, in order not to affect the loadbearing capacity of individual elements and the overall stability of the structure.

4.4 When panels are used to construct the inner leaf of an external cavity wall, the outer masonry leaf and all masonry below the dpc must be designed and constructed in accordance with BS EN 1996-1-1 : 2005, BS EN 1996-1-2 : 2005 and BS EN 1996-2 : 2006 and their UK National Annexes, and PD 6697 : 2019. When the panels are used in a roof, the roof tiles and slates must be applied in accordance with BS 5534 : 2014.

4.5 Other wall and roof weatherproofing systems can be used, but are not covered by this Certificate.

4.6 Foundations (outside the scope of this Certificate) must be approved for use by the Certificate holder's technical staff and should be suitably level and square to accept the system.

Figure 1 Typical wall and roof construction

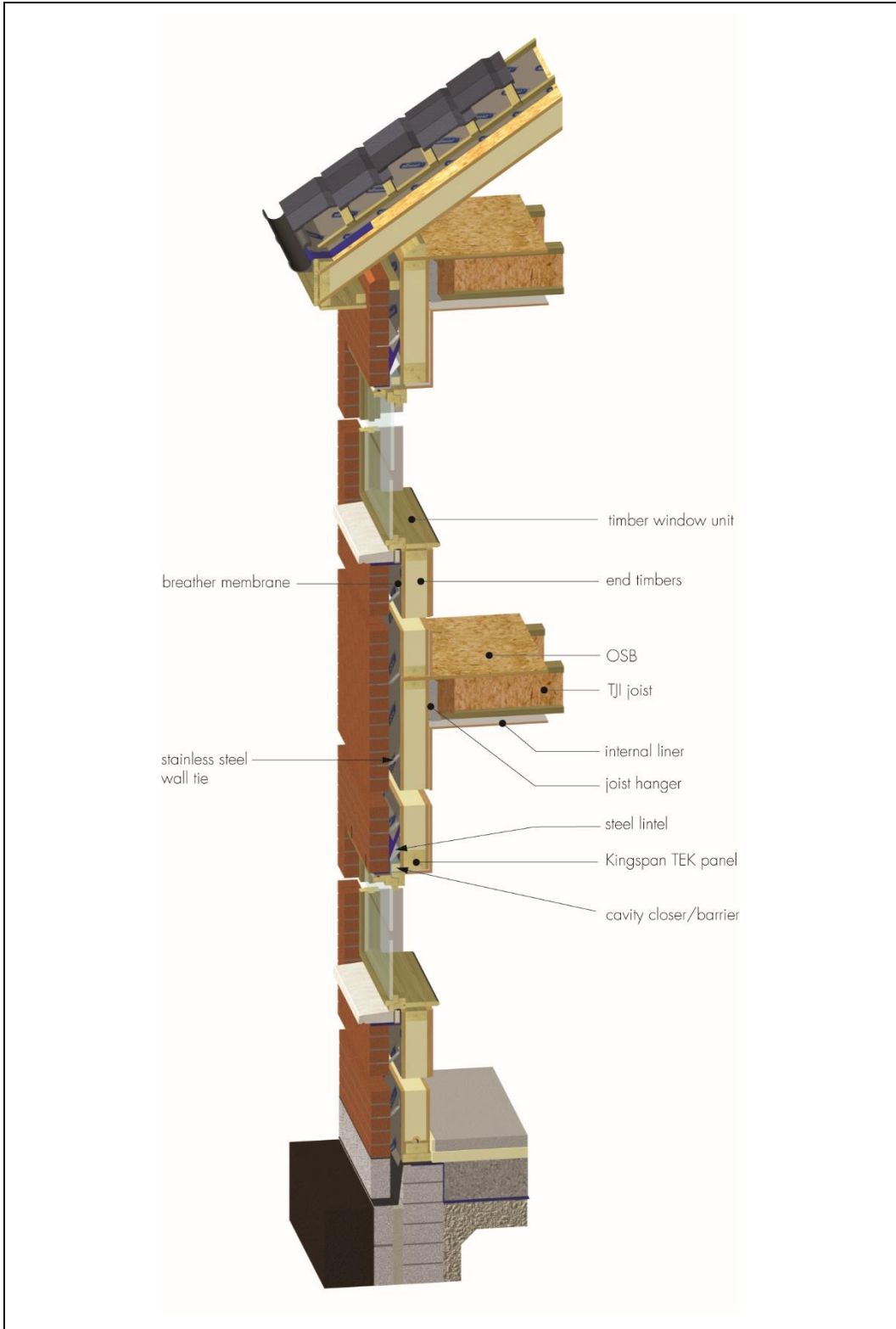

Figure 2 Cassette joint system

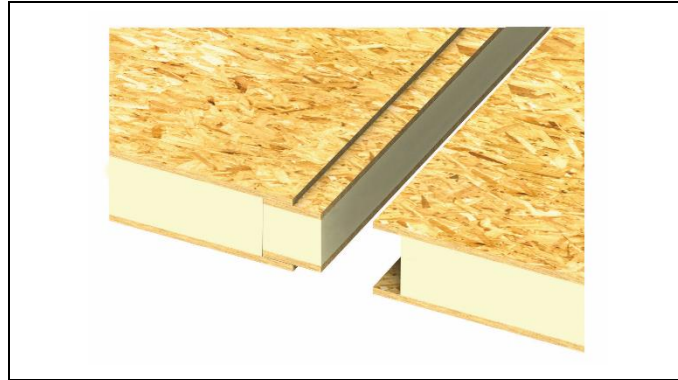

Table 1 Applications

Application	1 storey	2 storeys	3 storeys	4 storeys
Standard trussed rafters	✓	✓	✓	✓
Attic trusses	✓	✓	✓	✗
TEK roof (non-habitable, minimum pitch 1.15°)	✓	✓	✓	✓
TEK room-in-the-roof	✓	✓	✓	✗

5 Practicability of installation

The system should only be installed by installers who have been approved by the Certificate holder.

6 Strength and stability



6.1 The wall and roof panels will have adequate strength and stiffness to sustain the applied loading when used in accordance with the provisions of this Certificate. When using the panels, building designers must take account of the long-term creep effects of permanent loading and cracking to internal finishes and the shear deformation. Due consideration must also be given to any fire-resistance restrictions (see section 9.1).

6.2 The limit state design values to be used when evaluating the design resistance of the panels in compliance with Eurocodes are given in Tables 2 and 3 of this Certificate. The system differs to standard timber frame, but is usually erected by timber frame erectors. For wall application, the OSB facing panels must be fully supported.

6.3 The strength of all connection details which tie walls to other structural elements (such as walls, floors, roofs and solid timber splines) must be evaluated and provide adequate stability and robustness for the overall building design (see Figure 3). The specification and design for these items must be determined by the suitably qualified Chartered Structural Engineer responsible for the overall stability of the building. Guidance on the design of connection details may be obtained from the Certificate holder.



6.4 Lintels and framing around openings form an integral part of the loadbearing wall panels (see Figure 4). The sizing of lintels should be determined by the Chartered Engineer responsible for the design. The formation of openings for windows and doors in panels should only be carried out under approved factory conditions, or alternatively on site, by using individual pre-engineered panels. The structural design of any buildings must take account of the reduction in loadbearing capacity of the panels and the overall stability of the building due to the number and location of openings. Small service openings (such as for pipework for flues) may only be made through the panels on site when agreed by the Certificate holder.

Table 2 Structural properties – limit state design⁽¹⁾ – TEK 142

Strength (per metre width of panel)		Duration of load				
		Permanent	Long	Medium	Short	Instantaneous
Bending strength perpendicular to plane of the panel ⁽²⁾ (M_{Rd})	kN·m	4.48	5.97	8.21	10.4	13.4
Shear strength ⁽²⁾ (V_{Rd})	kN	3.81	7.62	11.4	15.2	15.2
Bearing strength perpendicular to plane of the panel ⁽³⁾ (B) min. 45 mm bearing	kN	3.66	7.32	11.0	14.6	14.6
Axial strength (N) ⁽⁴⁾						
wall height <2400 mm	kN	38.5	50.8	57.9	64.7	78.1
wall height 2400 – 2700 mm	kN	33.4	44.4	57.9	64.7	78.1
wall height 2700 – 3000 mm	kN	29.0	38.8	57.9	64.7	78.1
wall height 3000 – 3500 mm	kN	23.3	31.4	47.6	64.7	78.1
wall height 3500 – 4000 mm	kN	18.9	25.7	39.3	64.7	78.1
wall height 4000 – 4800 mm	kN	14.0	19.2	29.6	50.4	62.6
Racking strength ⁽⁵⁾⁽⁶⁾⁽⁷⁾ (R) with $\phi 2.8 \times 63$ mm smooth nails to each face						
75 mm nail centres	kN	N/A	N/A	N/A	8.89	10.9
100 mm nail centres	kN	N/A	N/A	N/A	7.42	9.07
150 mm nail centres	kN	N/A	N/A	N/A	5.58	6.82
Stiffness (per metre width of panel)⁽⁸⁾⁽⁹⁾⁽¹⁰⁾						
EI_{inst}	N·mm ²	4.60E+11				
Deformation factor due to bending ($k_{def, EI}$)	–	1.87				
GA_{inst}	N	5.70E+05				
Deformation factor due to shear ($k_{def, GA}$)	–	6.45				

- (1) The strength values in this Table are design values that should be compared to the worst loading case at the Ultimate Limit State (ULS)
- (2) When checking a panel under combined loading (axial + bending), the interaction formula $N_{Ed} / N_{Rd} + M_{Ed} / M_{Rd} \leq 1.0$ (where N_{Ed} and M_{Ed} are calculated from design loads, and N_{Rd} and M_{Rd} are taken from the values in the above Table). The deflection of the panel should also be checked to ensure it is within appropriate limits
- (3) The bearing strength (B) should be used where a panel spans continuously over a central support. The bearing strength at an end support should be resisted by including an edge timber in the panel at the support
- (4) Structural insulated panels transfer any in-plane forces through the OSB/3 outer skin. The facing OSB/3 skin is to be fully supported on both faces of the panel, typically bearing directly on the top and bottom sill
- (5) Racking resistance is influenced by the spacing of fixing nails around the perimeter (minimum 50 mm, maximum 150 mm). The racking resistance for other nail spacing can be calculated – the Certificate holder’s advice should be sought
- (6) Racking resistance was calculated according to BS EN 1991-1-1 : 2002, Method B. The fixing spacing factor (k_s) is included in the racking resistance values, but the wall shape factor (k_d) and the load factor ($k_{1,q}$) must be applied to the strength values
- (7) The dimension of nails given for the racking resistance relates to machine-driven nails with tensile strength of 600N·mm⁻². The capacity of other fixings can be calculated in accordance with BS EN 1995-1-1 : 2004, Method B
- (8) The stiffness values and deflection factors must be used to calculate the instantaneous and final deflection according to BS EN 1995-1-1 : 2004
- (9) The deflection due to shear must be taken into account
- (10) An appropriate deflection limit should be defined for each project on a case-by-case basis.

Table 3 Structural properties – limit state design⁽¹⁾ – TEK 172

Strength (per metre width of panel)		Duration of load				
		Permanent	Long	Medium	Short	Instantaneous
Bending strength perpendicular to plane of the panel ⁽²⁾ (M_{Rd})	kN·m	5.53	5.97	8.21	10.4	13.4
Shear strength ⁽²⁾ (V_{Rd})	kN	4.71	9.42	14.1	18.8	18.8
Bearing strength perpendicular to plane of the panel ⁽³⁾ (B) min. 45 mm bearing	kN	3.66	7.32	11.0	14.6	14.6
Axial strength (N) ⁽⁴⁾						
wall height <2400 mm	kN	43.4	51.2	57.9	64.7	78.1
wall height 2400 – 2700 mm	kN	43.4	51.2	57.9	64.7	78.1
wall height 2700 – 3000 mm	kN	40.0	51.2	57.9	64.7	78.1
wall height 3000 – 3500 mm	kN	32.7	43.8	57.9	64.7	78.1
wall height 3500 – 4000 mm	kN	27.0	36.4	55.2	64.7	78.1
wall height 4000 – 4800 mm	kN	20.4	27.7	42.4	64.7	78.1
Racking strength ⁽⁵⁾⁽⁶⁾⁽⁷⁾ (R) with $\phi 2.8 \times 63$ mm smooth nails to each face						
75 mm nail centres	kN	N/A	N/A	N/A	8.89	10.9
100 mm nail centres	kN	N/A	N/A	N/A	7.42	9.07
150 mm nail centres	kN	N/A	N/A	N/A	5.58	6.82
Stiffness (per metre width of panel)⁽⁸⁾⁽⁹⁾⁽¹⁰⁾						
EI_{inst}	N·mm ²	7.02 E+11				
Deformation factor due to bending ($k_{def, EI}$)	–	1.87				
GA_{inst}	N	6.89E+05				
Deformation factor due to shear ($k_{def, GA}$)	–	6.45				

- (1) The strength values in this Table are design values that should be compared to the worst loading case at the ULS
- (2) When checking a panel under combined loading (axial + bending), the interaction formula $N_{Ed} / N_{Rd} + M_{Ed} / M_{Rd} \leq 1.0$ (where N_{Ed} and M_{Ed} are calculated from design loads and N_{Rd} and M_{Rd} are taken from the values in the above Table). The deflection of the panel should also be checked to ensure it is within appropriate limits
- (3) The bearing strength (B) should be used where a panel spans continuously over a central support. The bearing strength at an end support should be resisted by including an edge timber in the panel at the support
- (4) Structural insulated panels transfer any in-plane forces through the OSB/3 outer skin. The facing OSB/3 skin is to be fully supported on both faces of the panel, typically bearing directly on the top and bottom sill
- (5) Racking resistance is influenced by the spacing of fixing nails around the perimeter (minimum 50 mm, maximum 150 mm). The racking resistance for other nail spacing can be calculated – the Certificate holder’s advice should be sought
- (6) Racking resistance was calculated according to BS EN 1991-1-1 : 2002, Method B. The fixing spacing factor (k_s) is included in the racking resistance values, but the wall shape factor (k_d) and the load factor ($k_{1,q}$) must be applied to the strength values
- (7) The dimension of nails given for the racking resistance relates to machine-driven nails with tensile strength of 600N·mm⁻². The capacity of other fixings can be calculated in accordance with BS EN 1995-1-1 : 2004, Method B
- (8) The stiffness values and deflection factors must be used to calculate the instantaneous and final deflection according to BS EN 1995-1-1 : 2004
- (9) The deflection due to shear must be taken into account
- (10) An appropriate deflection limit should be defined for each project on a case-by-case basis.

Figure 3 Basic panel design criteria⁽¹⁾

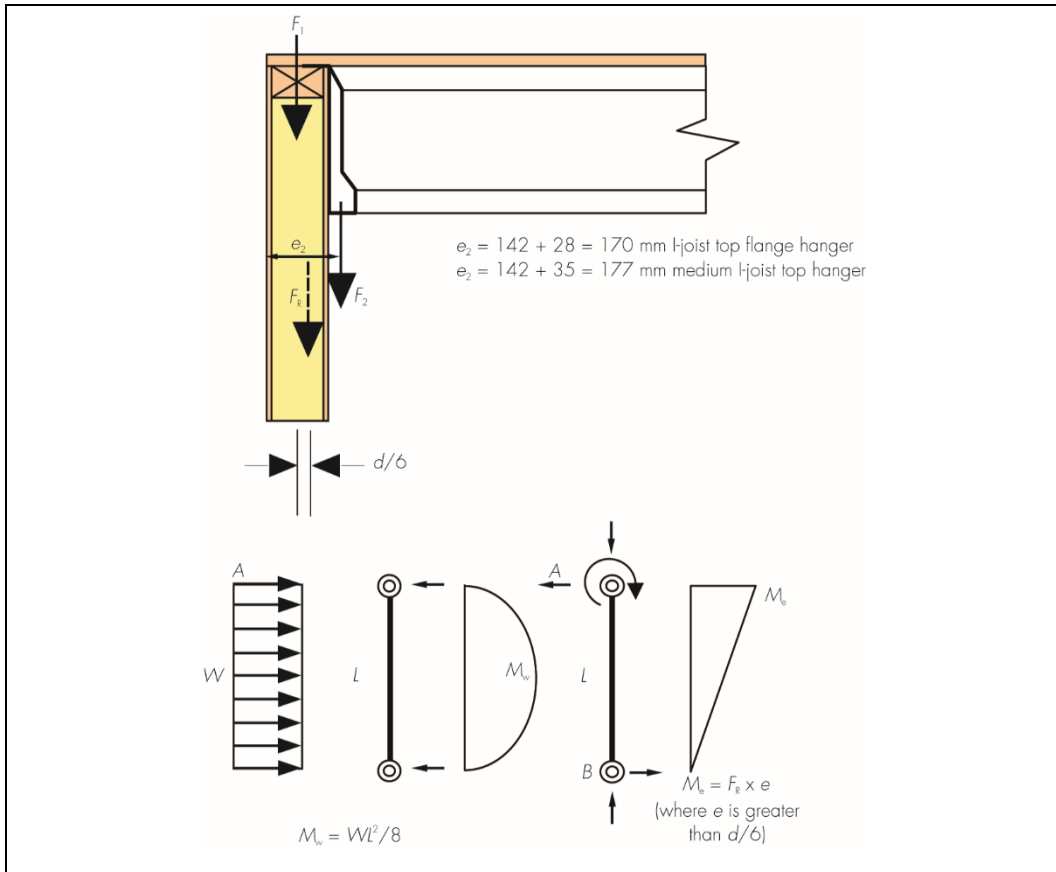

(1) These calculations assess the performance of the TEK wall panel only. Ancillary timbers and posts are assessed separately and may be used to enhance the overall performance of the panel.

Figure 4 External wall window detail including lintel

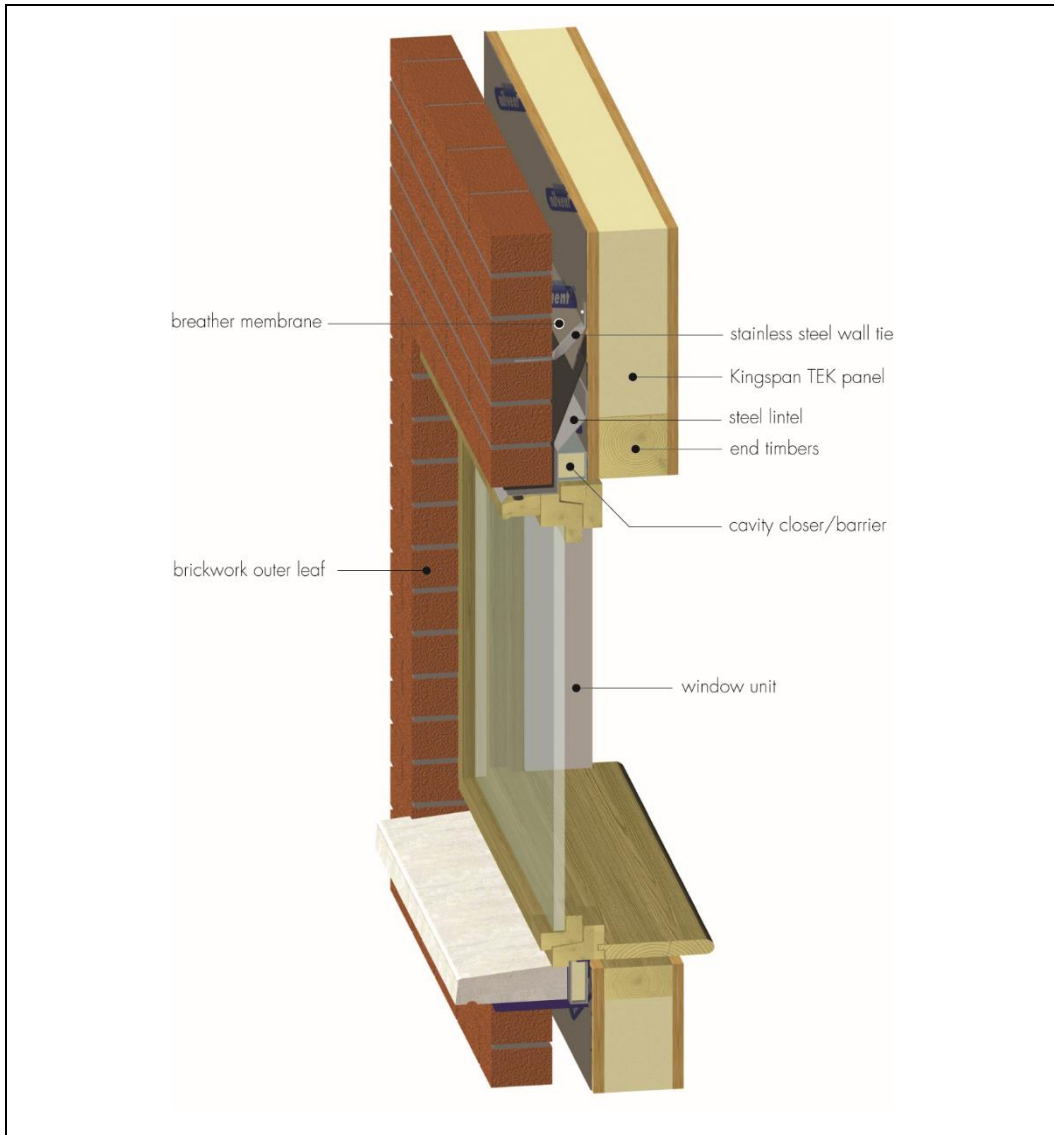

6.5 When the panels are used to construct the inner leaf of an external cavity wall, the outer masonry leaf and all masonry below the dpc must be designed and constructed in accordance with BS EN 1996-1-1 : 2005, BS EN 1996-1-2 : 2005, BS EN 1996-2 : 2006 and BS EN 1996-3 : 2006, and their UK National Annexes, and PD 6697 : 2019. The external wall design detail with the TEK wall panel to be included as the inner leaf, is shown in Figure 5.

Figure 5 External wall detail

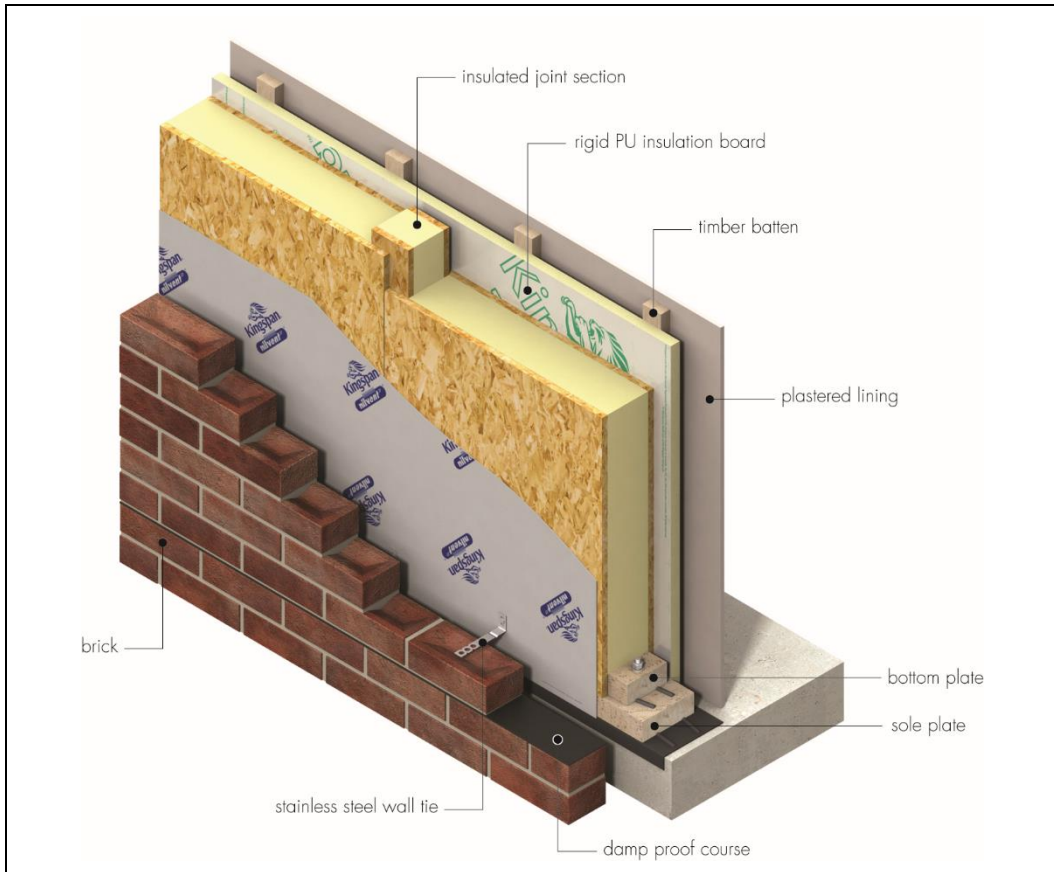

6.6 As part of the structural design, consideration should be given to the support of eccentric loads imparted by central heating systems or kitchen appliances.

6.7 Stainless steel wall ties can be directly attached to the OSB/3 face of the panel using flange-head 4 by 30 mm stainless steel screws, pozi-drive or as approved by the Certificate holder.



6.8 The structure incorporating the system must be designed by an appropriately qualified Chartered Structural Engineer, to satisfy the requirements of disproportionate collapse in national Building Regulations and BS EN 1991-1-7 : 2006 (Consequence class 1) and its UK National Annex.

6.9 The provisions for service penetrations (eg holes or notches) through roof panels will affect the design assumptions (see Tables 2 and 3). Further advice must be sought from the Certificate holder.

7 Thermal performance



7.1 Calculations of thermal transmittance (U value) should be carried out in accordance with BS EN ISO 6946 : 2017 and BRE Report BR 443 : 2006, using the thermal conductivities ($W \cdot m^{-1} \cdot K^{-1}$) as listed below, or the panel R-values in Table 4 of this Certificate.

PUR insulation	0.024 ⁽¹⁾
OSB	0.13
Solid timber	0.12
(1) λ_0	

Table 4 Example panel thermal resistance (R) values ($m^2 \cdot K \cdot W^{-1}$)

Element	Wall		Roof	
	Panel thickness (mm)	142	172	142
Solid timber bridging fraction	4%		1%	
Tek Panel R value ($m^2 \cdot K \cdot W^{-1}$) ⁽¹⁾	4.237	5.317	4.584	5.788

(1) In accordance with section 7 'SIPS' of BR 443 : 2006 and additionally including cassette spline (see Figure 2 of this Certificate) bridging fractions of 2.6% for walls and 5.6% for roofs. These panel R values may be used in combined U value calculations when the stated solid timber and cassette spline bridging fractions are not exceeded.

7.2 The U value of a complete element will depend on the selected panel thickness, the amount of timber bridging and the internal and external finishes. Calculated U values for example constructions are given in Table 5.

Table 5 Example element thermal transmittance (U) values ($W \cdot m^{-2} \cdot K^{-1}$)

Element ⁽¹⁾	Wall ⁽²⁾		Roof ⁽³⁾	
	Panel thickness (mm)	142	172	142
Element U value ($W \cdot m^{-2} \cdot K^{-1}$)	0.20	0.16	0.20	0.16

- (1) Includes a 25 mm services cavity (11.8% timber battens $\lambda = 0.13 W \cdot m^{-1} \cdot K^{-1}$) and 15 mm plasterboard $\lambda = 0.25 W \cdot m^{-1} \cdot K^{-1}$
 (2) Includes 102.5 mm brickwork, 50 mm vented cavity, breather membrane, TEK panel with 4% solid timber bridging and 2.6% cassette spline bridging and the internal finish in note (1), above
 (3) Includes slates/tiles, well-ventilated air space, LR roof tile underlay, TEK panel with 1% solid timber bridging and 5.6% cassette spline bridging and the internal finish in note (1), above

7.3 The system can contribute to maintaining continuity of thermal insulation around openings and between panels. Care must be taken in the overall design and construction of junctions with other elements to minimise thermal bridges and air infiltration. Detailed guidance can be found in the documents supporting the national Building Regulations.

8 Condensation

Surface condensation



8.1 The risk of surface condensation under normal domestic use is acceptable for elements, junctions and openings in accordance with section 7.3.

Interstitial condensation



8.2 Elements will adequately limit the risk of interstitial condensation when they are designed and constructed in accordance with BS 5250 : 2011 (Annexes D, F, G and H), and for flat roofs, BS 6229 : 2018, using the following water vapour diffusion factors (μ):

- 50 OSB warm side
- 60 PUR foam core
- 30 OSB cold side

8.3 Example calculations for the constructions in Table 5 of this Certificate for humidity Class 4 (high occupancy dwellings) indicate that any interstitial condensation forming will dissipate.

8.4 For flat roof build-ups, a separate air and vapour control layer (AVCL) on the warm side and a cross-ventilated cavity on the cold side of the panel/breather membrane are an essential part of the construction.

8.5 In roofs, a vapour permeable membrane with a maximum vapour resistance of $0.25 MN \cdot s \cdot g^{-1}$ should be used; for walls, a breather membrane with a maximum vapour resistance of $0.6 MN \cdot s \cdot g^{-1}$ should be used.

8.6 The risk of interstitial condensation in both the external walling and roofing is greatest when the building is drying out after construction. Guidance on preventing condensation is given in BRE Digest 369 and BRE Report BR 262 : 2002.

9 Behaviour in relation to fire

Reaction to fire



9.1 The Certificate holder has not declared a reaction to fire classification for the panels to BS EN 13501-1 : 2018.

9.2 Cavity barriers should be applied in accordance with the relevant national Building Regulations.



9.3 The panels should not be used in external walls of buildings that have a storey at least 18 m above ground level.



9.4 In Scotland, the panels may be used in external walls of buildings with no storey more than 18 m above the ground, and more than 1 metre from a boundary. The panels should not be used as infill panels in external walls of buildings with a story more than 11 m above the ground.

Resistance to fire



9.5 When tested to BS EN 1365-1 : 2012 and classified in accordance with BS EN 13501-2 : 2016, the 142 Kingspan TEK panel system achieved the results shown in Table 6 of this Certificate. For full details on the fire test reports, the Certificate holder should be contacted.

Table 6 Resistance to fire classification to BS EN 13501-2 : 2016

Performance	Applied load (kN)	Construction	Test report reference number
REI30	38.5	3000 x 3000 x 179.5 mm (w x h x t) wall consisting of 12.5 mm thick Type A plasterboard, eg Knauf, fixed over 38 mm x 25 mm C16 soft wood grade battens fixed to the exposed face of the 142 mm TEK panel	Efectis UK/Ireland Classification Report EUI-19-B-000198 ⁽¹⁾
REI60	38.3	3010 x 2400 x 179.5 mm (w x h x t) wall consisting of 15 mm thick gypsum Type F board, eg Firecheck, fixed over 25 mm thick x 50 mm wide softwood battens fixed to the exposed face of the 142 mm TEK panel	WF Test Report no. 345653 and WF Classification Report no. 370193 Iss 2

(1) The results of the fire test are directly applicable to similar constructions incorporating any of the below changes, where the construction continues to comply with the appropriate design code for its stiffness and stability:

- the height may be decreased
- the thickness of the wall may be increased
- the thickness of component materials may be increased
- the linear dimensions of boards or panels may be decreased, apart from their thickness
- the number of fixings used to attach the panels to supporting constructions may be increased and the distance between fixings may be reduced
- the load may be decreased.

9.6 Where any other form of wall construction incorporating the panels (including any service penetrations) is subject to fire resistance requirements, an appropriate assessment or test must be carried out by a UKAS-approved (United Kingdom Accreditation Service) testing laboratory.

Roofs

9.7 The resistance to external fire exposure of a roof incorporating the panels will depend on the specification of the roof covering used.

Junctions



9.8 Junctions between walls incorporating the panels, or other fire-resisting element, must maintain the required period of fire resistance.

9.9 Where the panels are to be 'carried over' compartment walls, designers must ensure that the roof/wall junction detail provides sufficient resistance to fire penetrating into the neighbouring compartment.

Figure 6 Separating wall details

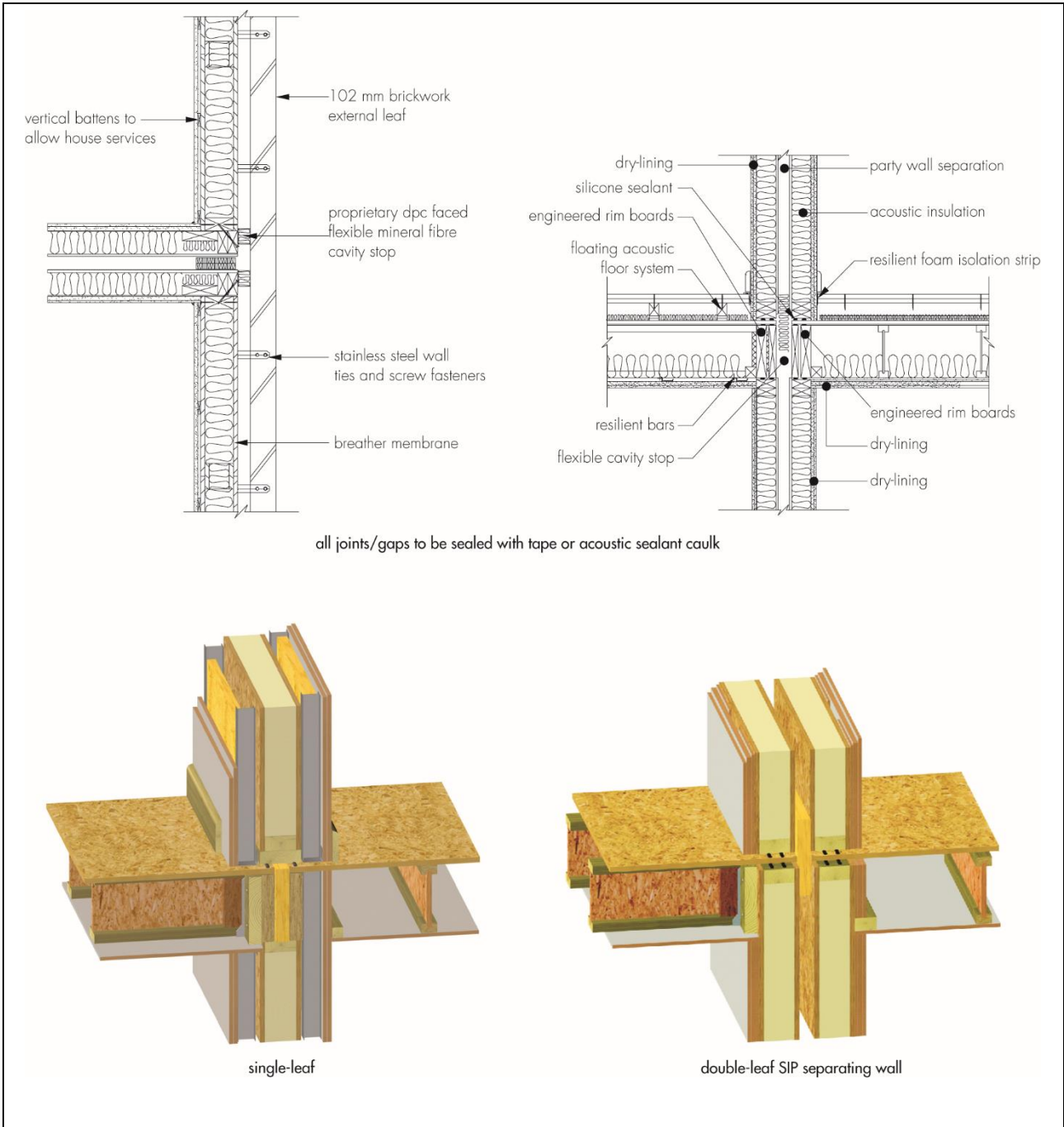

10 Air permeability



10.1 The panels can contribute to achieving adequate resistance to unwanted air infiltration provided there is effective sealing around junctions.

10.2 A proportion of completed buildings in a development is subject to pre-completion airtightness testing. Exceptions for small developments can be found in the documents supporting the national Building Regulations.

11 Proximity of flues and appliances

Detailed guidance can be found in the documents supporting the national Building Regulations for the provisions that are applicable when the system is installed in close proximity to certain flue pipes and/or heat-producing appliances.

12 Resistance to airborne sound



12.1 Separating walls may be in the form of single or double party walls and are subject to pre-completion testing.

12.2 Wall panels may be used in combination with Robust Details Ltd timber separating walls E-WT-1 and E-WT-2 (see Robust Details, Appendix A2). Reference should also be made to the Certificate holder's Standard Details.

12.3 Good working practices should be adopted for sealing all joints with caulk or tape. Double or treble layers of plasterboard should be staggered. Relevant practices detailed within the relevant regulatory guidance must be adopted.

12.4 It is essential that care is taken in the design and during installation to avoid direct paths for airborne sound transmission and to minimise paths for flanking sound transmission.

13 Weathertightness

13.1 When the panels are used to form the inner leaf of an external cavity wall, the outer masonry leaf must be designed and constructed in accordance with BS EN 1996-1-1 : 2005, BS EN 1996-2 : 2006 and BS EN 1996-3 : 2006 and their UK National Annexes and PD 6697 : 2019, and must incorporate damp-proof courses and cavity trays. A breather membrane is required with this type of construction.

13.2 When used with other outer leaf construction, the final weather resistance of the building is dependent upon the efficient positioning and sealing of all joints. The guidance given in BRE Report BR 262 : 2002, Section 3, should be followed with regard to rain penetration – the designer must select a construction appropriate to the local wind-driven rain index, paying due regard to the design detailing, workmanship and materials to be used.

13.3 Roofing should be detailed in accordance with BS 5534 : 2014 to ensure moisture is prevented from coming into contact with the panels.

13.4 The minimum cavity widths between the wall panel outer face and the back of cladding/external finishes should be in accordance with the requirements of the NHBC Standards.

14 Maintenance and repair



Although maintenance is not envisaged for the panels, regular checks should be carried out on the finishes to ensure that any damage is detected and repaired as soon as possible.

15 Durability



15.1 The panels will have comparable durability to that of OSB/3 to BS EN 300 : 2006. Therefore, provided the installation remains weathertight and damp-proof, a service life of at least 60 years may be expected.

15.2 Timber used in areas that could be at risk, eg sole plates, should be preservative-treated in accordance with the recommendations given in BS 8417 : 2011.

Installation

16 General

16.1 Erection of the Kingspan TEK wall and roof panels must comply with the details given in the Certificate holder's construction manual, and the provisions of this Certificate.

16.2 When used in loadbearing applications, the main contractor must ensure that the accuracy of the foundation is in accordance with the Certificate holder's instructions. In particular, the following details must be within the tolerance of ± 5 mm:

- level of the foundation or other bearing support
- overall width and length of the building footprint
- diagonals used for checking the overall squareness of the building⁽¹⁾.

(1) Adjustment may be possible through the sole plates.

16.3 When using the SIP as an infill panel, the main contractor must ensure that the accuracy of the structural frame is in accordance with the Certificate holder's acceptable tolerances:

- panels to be held in place with proprietary brackets to the Chartered Structural Engineer's specification
- a 5 mm gap should be left at the head of the infill panel to allow for expansion/differential movement. The gap should be filled with an expanding urethane foam or proprietary compressible foam.

16.4 Guidance on the procedures for installing the infill panels is limited due to the variations in the structural frame construction and detailing. Erection methods for lifting the non-load bearing wall panels into place, specification and design of brackets, and fixings and tolerances will therefore need to be determined by the Project Design Engineer for each structure in which the infill wall panels are used. Further guidance can be obtained from the Certificate holder (see Figure 9 and section 17.8).

17 Procedure (loadbearing construction)

Foundation construction

17.1 A suitable dpc must be laid on top of the foundation, with 2 beads of silicone sealant applied to the top surface.

17.2 A 40 mm deep, treated softwood (C24) sole plate is combined with a 40 mm deep bottom plate, positioned over the dpc and fixed to the foundation using fixings approved by the Certificate holder and as per the Chartered Structural Engineer's requirements. Tolerances for sole plates can be adjusted as per *Kingspan TEK Technical Bulletin No 5* or the Certificate holder's recommendations. Proprietary injectable mortar grouting is used to seal against air infiltration.

Ground-floor construction

17.3 A bead of expanding urethane sealant is run along the top of the sole plate/bottom plate or in the route of the panel(s). Starting at one corner, the first panel is positioned correctly on the combination sole plate and fixed to the bottom plate section with nails/screws (as approved by the Certificate holder) through the OSB inner and outer skins. Any building grade PU foaming adhesive is suitable for this application. This forms the standard basis for connecting panel-to-panel runs, panel/intermediate floor joints or timber-to-timber at corner junctions. Panels are temporarily

braced to maintain stability. Beads of adhesive are applied to the bottom and vertical recesses of subsequent panels and fitted together, plumbed and secured with nails.

Internal wall construction

17.4 Wall panels are generally assembled horizontally, using a cassette joint, which is also sealed using expanding urethane. Joints of the panel are tightened. Timber lintels, where required, are fixed into position over openings. A continuous timber head plate is fitted into the rout at the top of panels. Generally, all timber to rigid urethane core connections are sealed using expanding urethane. All timber-to-timber connections are sealed using two beads of silicone sealant.

Internal floor construction

17.5 Engineered or traditional timber floor joists can be supported on the panel by either adopting a rim board detail or securing with joist hangers (see Figure 7). OSB/3 (22 mm thick) or P5 particle board floor decking is fixed over the engineered joist and head plate/rim board as appropriate. The panel system is protected externally using a vapour permeable membrane (see section 8.5). A sole plate or bottom plate (as per design requirements) is seated on silicone sealant and attached through the floor decking into the head plate/rim board. The process continues in the same manner as for the ground-floor construction.

Figure 7 Internal floor detail

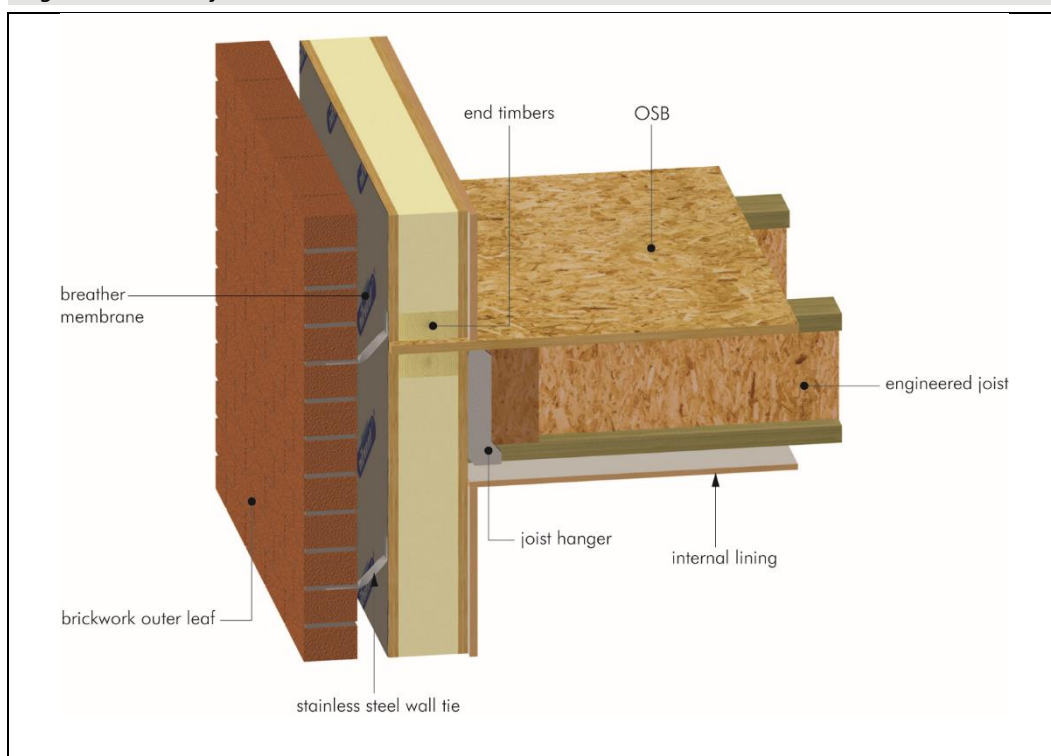

Roof construction

17.6 The supporting walls are made fully rigid by nail/screw fixings as approved by the Certificate holder, and intermediate/ridge beams/purlins in accordance with the design requirements, which are incorporated within preformed pockets in the wall panel. A wall plate is fixed onto the top of the head plate, the top of which is angled to suit the pitch of the roof.

17.7 Roof panels are positioned via mechanical handling, working from one gable wall to the other. Panels are joined (as for the wall construction) and fixed through to the structural supporting timber members using FastenMaster Headlok fasteners to the Chartered Engineer's design requirements. The roof panel is overlaid with a vapour permeable membrane (see section 8.5). Treated softwood counter battens (minimum 25 mm deep by 50 mm wide) are fixed through to the roof panel using stainless steel screws as approved by the Certificate holder and at centres to the Chartered Engineer's design requirements. A variety of roof finishes (see section 1.5) can be adopted, subject to the Certificate holder's approval (see Figure 8).

Figure 8 Typical roof detail, with and without membrane application

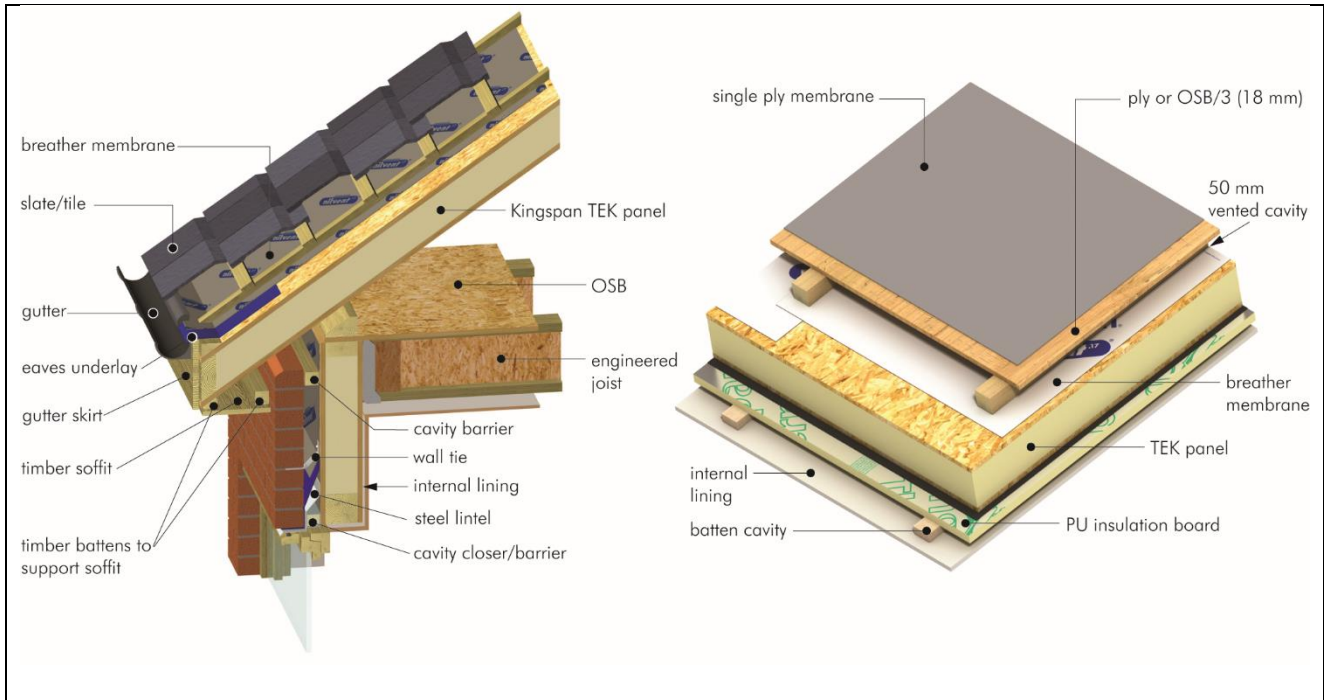

Infill panel application

17.8 The panels are prepared in the same way as for the wall panels (described in section 17.4). The panels can be fixed inside the structural frame of a building, as an infill panel between structural load-bearing elements (eg concrete posts). Typically, the panel is secured to the structural frame using dead bolt fixings. At floor level, the dead bolts are fixed through the panels to a continuous steel angle bracket; at ceiling level, they are fixed through the panels to angled cleats with slotted fixing connections, to allow for differential movement. A high-performance insulation should be fixed to the external face of the floor slab to reduce thermal bridging through the structural frame of the building (see Figure 9).

Figure 9 Infill panel

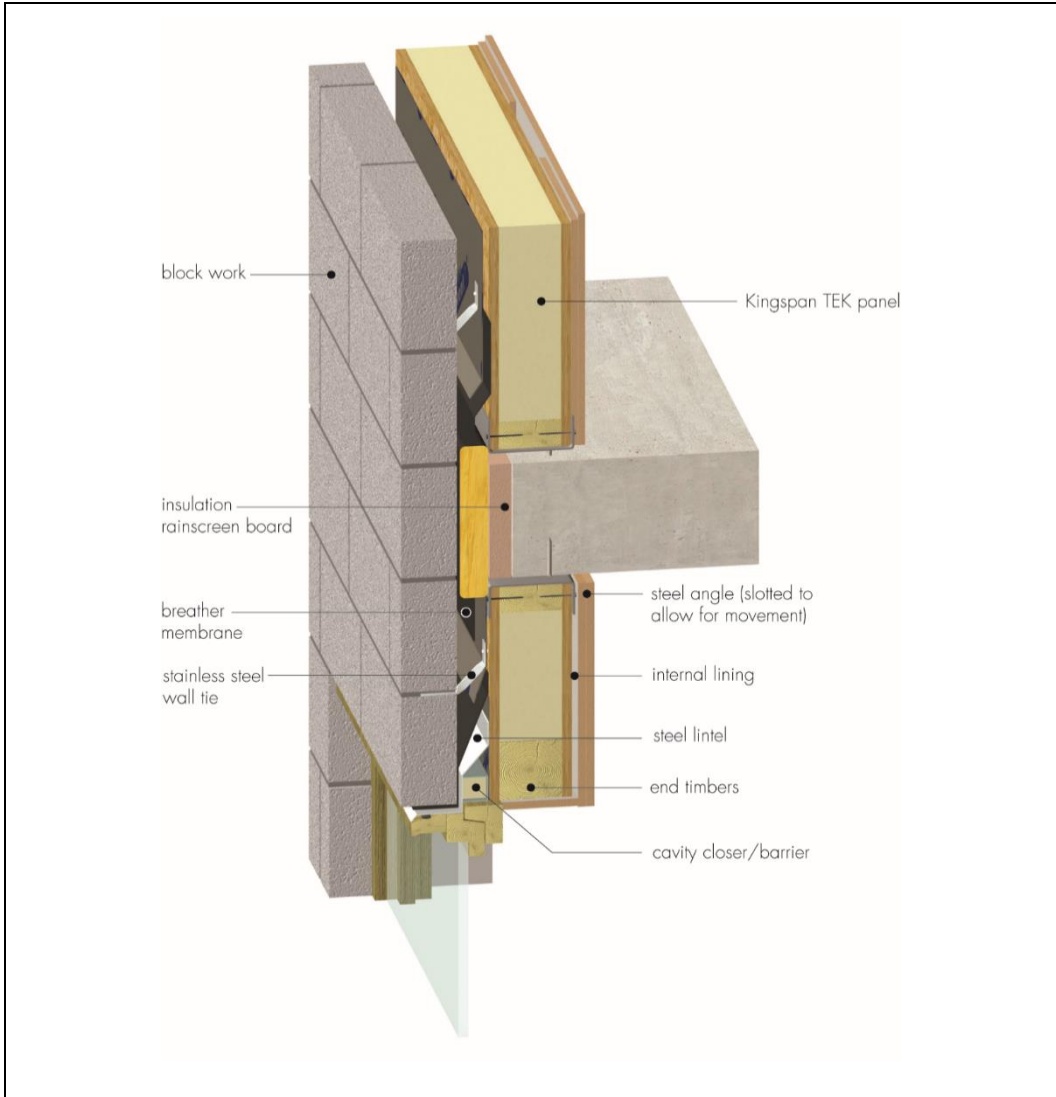

18 Tests

Tests were carried out and the results assessed to determine:

- vertical loading
- pull-out strength of wall ties
- fire-resistance.

19 Investigations

19.1 An examination was made of technical data relating to:

- structural properties and design calculations
- airborne sound insulation tests
- air leakage tests.

19.2 The manufacturing process was evaluated, including the methods adopted for quality control, and details were obtained of the quality and composition of the materials used.

19.3 Visits were made to a number of sites in the UK to assess the installation processes.

19.4 A condensation risk assessment to BS 5250 : 2011 was undertaken for a typical wall and roof construction.

Bibliography

BRE Digest 369 *Interstitial condensation and fabric degradation*

BRE report BR 262 : 2002 *Thermal insulation: avoiding risks*

BRE report BR 443 : 2006 *Conventions for U-value calculations*

BS 5250 : 2011 + A1 : 2016 *Code of practice for control of condensation in buildings*

BS 5534 : 2014 + A2: 2018 *Slating and tiling for pitched roofs and vertical cladding — Code of practice*

BS 6229 : 2018 *Flat roofs with continuously supported coverings — Code of practice*

BS 8000-3 : 2001 *Workmanship on building sites — Code of practice for masonry*

BS 8215 : 1991 *Code of practice for design and installation of damp-proof courses in masonry construction*

BS 8417 : 2011 + A1 : 2014 *Preservation of wood — Code of practice*

BS EN 300 : 2006 *Oriented Strand Boards (OSB) — Definitions, classification and specifications*

BS EN 336 : 2013 *Structural timber — Sizes, permitted deviations*

BS EN 338 : 2016 *Structural timber — Strength classes*

BS EN 845-1 : 2013 + A1: 2016 *Specification for ancillary components for masonry — Wall ties, tension straps, hangers and brackets*

BS EN 1365-1 : 2012 *Fire resistance tests for loadbearing elements — Walls*

BS EN 13501-1 : 2018 *Fire classification of construction products and building elements — Classification using data from reaction to fire tests*

BS EN 13501-2 : 2016 *Fire classification of construction products and building elements — Classification using data from fire resistance tests, excluding ventilation services*

BS EN 13963 : 2014 *Jointing materials for gypsum boards — Definitions, requirements and test methods*

BS EN 15651-1 : 2017 *Sealants for non-structural use in joints in buildings and pedestrian walkways – Sealants for facade elements*

BS EN 1991-1-1 : 2002 *Eurocode 1 : Actions on structures – General actions – Densities, self-weight, imposed loads for buildings*

BS EN 1991-1-7 : 2006 + A1 : 2014 *Eurocode 1 : Actions on structures – General actions – Accidental actions*
NA + A1 : 2014 to BS EN 1991-1-7 : 2006 + A1 : 2014 *Eurocode 1 : Actions on structures – General actions – Accidental actions*

BS EN 1995-1-1 : 2004 + A2 : 2014 *Eurocode 5 : Design of timber structures – General – Common rules and rules for buildings*

BS EN 1996-1-1 : 2005 + A1 : 2012 *Eurocode 6 : Design of masonry structures – General rules for reinforced and unreinforced masonry structures*
NA to BS EN 1996-1-1 : 2005 + A1 : 2012 *Eurocode 6 : Design of masonry structures – General rules for reinforced and unreinforced masonry structures*

BS EN 1996-1-2 : 2005 + A2 : 2014 *Eurocode 5 : Design of timber structures – General – Common rules and rules for buildings*
NA to BS EN 1996-1-2 : 2005 + A2 : 2014 *UK National Annex to Eurocode 5 : Design of timber structures – General – Common rules and rules for buildings*

BS EN 1996-2 : 2006 *Eurocode 6 : Design of masonry structures – Design considerations, selection of materials and execution of masonry*
NA to BS EN 1996-2 : 2006 *UK National Annex to Eurocode 6 : Design of masonry structures – Design considerations, selection of materials and execution of masonry*

BS EN 1996-3 : 2006 *Eurocode 6 : Design of masonry structures – Simplified calculation methods for unreinforced masonry structures*
NA + A1 : 2014 to BS EN 1996-3 : 2006 *UK National Annex to Eurocode 6 : Design of masonry structures – Simplified calculation methods for unreinforced masonry structures*

BS EN ISO 9001 : 2015 *Quality Management Systems – Requirements*

BS EN ISO 6946 : 2017 *Building components and building elements – Thermal resistance and thermal transmittance – Calculation method*

PD 6697 : 2019 *Recommendations for the design of masonry structures to BS EN 1996-1-1 and BS EN 1996-2*

20 Conditions

20.1 This Certificate:

- relates only to the product/system that is named and described on the front page
- is issued only to the company, firm, organisation or person named on the front page – no other company, firm, organisation or person may hold or claim that this Certificate has been issued to them
- is valid only within the UK
- has to be read, considered and used as a whole document – it may be misleading and will be incomplete to be selective
- is copyright of the BBA
- is subject to English Law.

20.2 Publications, documents, specifications, legislation, regulations, standards and the like referenced in this Certificate are those that were current and/or deemed relevant by the BBA at the date of issue or reissue of this Certificate.

20.3 This Certificate will remain valid for an unlimited period provided that the product/system and its manufacture and/or fabrication, including all related and relevant parts and processes thereof:

- are maintained at or above the levels which have been assessed and found to be satisfactory by the BBA
- continue to be checked as and when deemed appropriate by the BBA under arrangements that it will determine
- are reviewed by the BBA as and when it considers appropriate.

20.4 The BBA has used due skill, care and diligence in preparing this Certificate, but no warranty is provided.

20.5 In issuing this Certificate the BBA is not responsible and is excluded from any liability to any company, firm, organisation or person, for any matters arising directly or indirectly from:

- the presence or absence of any patent, intellectual property or similar rights subsisting in the product/system or any other product/system
- the right of the Certificate holder to manufacture, supply, install, maintain or market the product/system
- actual installations of the product/system, including their nature, design, methods, performance, workmanship and maintenance
- any works and constructions in which the product/system is installed, including their nature, design, methods, performance, workmanship and maintenance
- any loss or damage, including personal injury, howsoever caused by the product/system, including its manufacture, supply, installation, use, maintenance and removal
- any claims by the manufacturer relating to CE marking.

20.6 Any information relating to the manufacture, supply, installation, use, maintenance and removal of this product/system which is contained or referred to in this Certificate is the minimum required to be met when the product/system is manufactured, supplied, installed, used, maintained and removed. It does not purport in any way to restate the requirements of the Health and Safety at Work etc. Act 1974, or of any other statutory, common law or other duty which may exist at the date of issue or reissue of this Certificate; nor is conformity with such information to be taken as satisfying the requirements of the 1974 Act or of any statutory, common law or other duty of care.